

Guidelines for Workshop Practice

### *Guidelines for installing multi-skin sheets*

PLEXIGLAS ALLTOP® SP  
PLEXIGLAS RESIST® SP  
PLEXIGLAS HEATSTOP® SP



**A word to start with**

Since the guidelines given here apply universally to all multi-skin sheets (= SP), i.e. double- and quadruple skin sheets (= SDP and S4P), contained in our sales range, we will simply speak of „sheets“.

Details concerning individual types of sheets are pointed out where appropriate.

**NB:** When preparing yourself for the installation of multi-skin sheets PLEXIGLAS® SP remember to ask your PLEXIGLAS® stockist for the special **Product Description leaflets** on the different types of sheets\*), the corresponding **PROFES-SIONAL glazing systems** and the **PROStyle® assembly system**.

**For your further guidance, we can also provide our leaflet entitled „Example of conservatory roof glazing with multi-skin sheets“ (Ref. No. 314-4).**

When using our products, you must also observe any

- building regulations,
- standards or
- codes of practice which apply.

All previous versions of this brochure are superseded by this issue.

Contents	Page
1 Transport and storage	3
2 Dimensions	4
3 Supporting structure	5
4 Heat build up	6
5 Compatibility with other materials	7
6 Cutting-to-size	8
7 Drilling	9
8 Installation	10/11
9 Behavior in use	12/13
10 Suppliers of ancillary products	14/15



\*) The aces in our range of multi-skin sheets:

The "Noble" Sheet<sup>1)</sup>  
 PLEXIGLAS ALLTOP® SDP

The "Tough" Sheet<sup>2)</sup>  
 PLEXIGLAS RESIST® SDP

The "Cool" Sheet<sup>3)</sup>  
 PLEXIGLAS HEATSTOP® SP

The "Snug" Sheet<sup>4)</sup>  
 PLEXIGLAS RESIST® S4P

<sup>1)</sup> European patent EP 530 617

<sup>2)</sup> European patent EP 733754

<sup>3)</sup> European patent EP 548822

## In a nutshell:

- Store only indoors or always thoroughly protected by white PE sheeting!
- Close open ends to prevent entry of dirt!

## In detail:

**1.1** The surfaces are covered with a protective masking on which you find hints for storage and installation and the name of the material. The exact grade is stamped on the sheet, near one of the long edges.

**1.2** During storage or transport, the sheet piles must be kept away from rain and sunlight. Even short-term exposure is to be avoided! Therefore they are best stored indoors. Out of doors they must be covered with white polyethylene sheeting. This applies also to opened pallets.

**1.3** Sheets not properly stored may develop crazes after installation.

**1.4** During transport and storage – as after installation – the open ends of the sheets must be **protected against the penetration of dust, dirt, water, insects, etc.** The sheets are additionally sealed at the open ends by the manufacturer (Caution: observe chapt. 8 for installation). If the sheets are cut on site after delivery, they have to be protected and sealed again in the described manner.

**1.5** To avoid breakage during loading and unloading, do not knock the sheets against edges or corners. If they are not stored on a pallet, a level support must be found for them as they cannot be stored directly on the ground. Otherwise please observe the instructions printed in several languages on the packing.

Fig. 1: Protective masking of sheet piles



### In a nutshell:

- Allow 5 mm/m with PLEXIGLAS ALLTOP® SP and 6 mm/m for expansion with PLEXIGLAS RESIST® SP and PLEXIGLAS HEATSTOP® SP!
- Centre-to-centre spacing of Röhm glazing systems = sheet width + 30 mm (or + 25 mm for other glazing systems)!

*In detail:*

**2.1** For thickness, widths and lengths of the sheets please consult our latest Sales Range.

**2.2** We supply the sheets with the following longitudinal tolerances ( $\Delta L$  in Fig. 2):  
sheets up to 3 m long – 0 + 6 mm,  
sheets over 3 m long – 0 + 2 mm/m.

**2.3** PLEXIGLAS® sheets expand due to heat and/or moisture and contract in a cold and/or dry climate. The sheet lengths are to be calculated in such a way that the sheets cannot slip out of the upper retaining or connecting sections in cold weather and are able to expand freely in warm weather in order to exclude damage by buckling, for example.

**2.4** If the sheets are installed at an ambient temperature of 10°C, for example, they will contract by up to 2.5 mm/m in the winter. For their expansion due to heat and moisture a **general allowance** should be made of

**6 mm/m for PLEXIGLAS RESIST® SP and PLEXIGLAS HEATSTOP® SP,  
5 mm/m for PLEXIGLAS ALLTOP® SP.**

**2.5** The sheet length to be ordered can be easily measured at the building site. It can also be more precisely calculated according to Fig. 2 and the following equations:

for PLEXIGLAS RESIST® SP and PLEXIGLAS HEATSTOP® SP:

$$L = E - \frac{8 \cdot E}{1000} - A$$

for PLEXIGLAS ALLTOP® SP:

$$L = E - \frac{7 \cdot E}{1000} - A$$

**2.6** The glazing bars used at the long sides of multi-skin sheets must be able to accommodate the inevitable variations in width and the expansion of the sheets due to heat and moisture.

The **Röhm glazing systems**, e.g. PROFESSIONAL THERMOGLAZING SYSTEM, PROFESSIONAL CLAMPING SYSTEM and PROFESSIONAL BASE-PLATE SYSTEM as well as the PROStyle® system, are to be spaced as follows:

centre-to-centre distance =  
sheet width + 30 mm

Other glazing systems for PLEXIGLAS® may have to be spaced differently (e.g. + 25 mm). Please enquire with the supplier.

Fig. 2: Order length

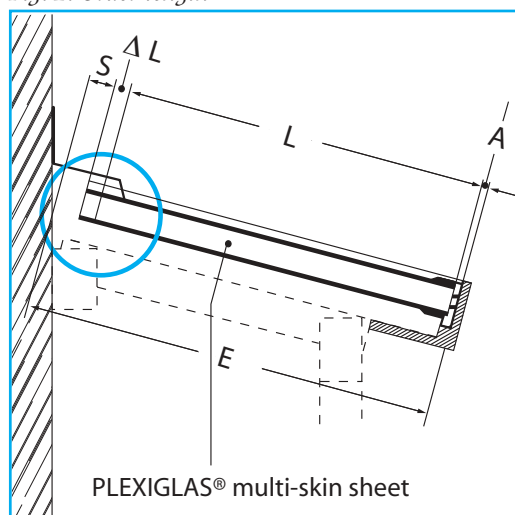

Explanation of symbols:

$L$  = order length in mm, to be specified with the PLEXIGLAS® stockist

$E$  = maximum clearance in mm between the lower stop and the upper limit (in doubtful cases to be checked on site beforehand)

$A$  = length in mm added by the lower end closure section (if also used at upper end, add to  $A$ )

$\Delta L$  = longitudinal tolerance according to sales range

$S$  = allowance for expansion (acc. to 2.4)

## In a nutshell:

- Min. roof pitch 5° (= 90 mm/m)!
- PLEXIGLAS RESIST® SP and PLEXIGLAS HEATSTOP® SP multi-skin sheets can also be installed in cold-curved position (not valid for PLEXIGLAS ALLTOP® double-skin sheets)!

*In detail:*

**3.1** The supporting structure has to be designed in accordance with the rules for construction in wood or metal. It must be stable and solid enough to bear all snow and wind loads at no risk for the sheets. In the case of wooden structures, in particular care must be taken that the supporting members **do not warp** in the course of time. For this reason laminated timber beams are more suitable than wooden beams.

**3.2** For a load bearing structure it must be borne in mind that the sheets have to be installed with their webs in the direction of the slope, i.e. of the water flow (Fig. 3a).

**3.3** In the case of roof glazing, only a minimum pitch of 5° (corresponding to 90 mm of slope per meter of sheet length) can guarantee that the

rain water flows off and the joints are tight (Fig. 3a). Since dirt can hardly cling to the smooth surfaces of PLEXIGLAS®, this minimum roof pitch normally also ensures that the roof is largely cleaned by the rain (see 9.7).

**3.4** Double-skin sheets of PLEXIGLAS ALLTOP® may **only be installed flat**.

Impact-modified types, instead, like PLEXIGLAS RESIST® SP and PLEXIGLAS HEATSTOP® SP can also be **installed in cold-curved position**, e.g. for barrel-vault roofing. The **minimum cold-curving radius of 150 x sheet thickness** may not fall below (Fig. 3b). When spacing the hoops, the expansion and the rebate or clamping depth of at least 15 mm must be borne in mind.

**3.5** Many substrates are varnished or painted. If so, they **must be dried** for some weeks before installing PLEXIGLAS® SP to prevent solvent vapors from attacking the sheets.

**3.6** Transverse butts are to be avoided! If possible, use sheets of roof length (cf. 2.5). Otherwise, design the substructure in such a way that two roof sections are obtained which overlap at a distance.

Fig. 3b: Principle of cold-curved roof glazing

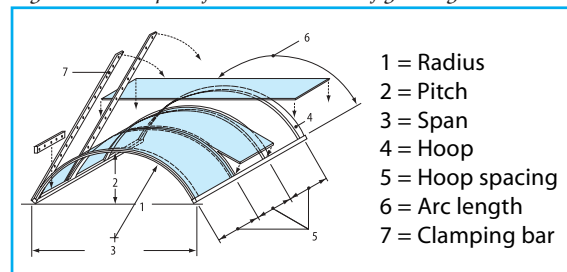
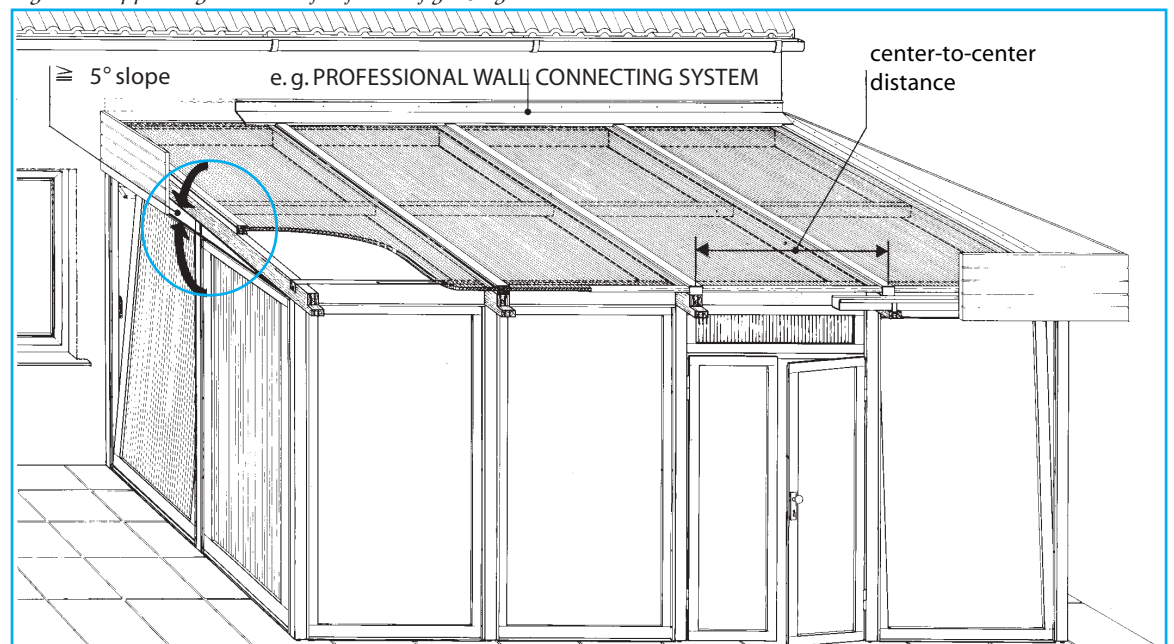

Fig. 3a: Supporting structure for flat roof glazing



## In a nutshell:

- All structural members facing the sheet must be provided with white or reflective surfaces (light fast emulsion paint or aluminum foil)!
- Use only clamping systems which are light in color (exception: additional cover sections)!

## In detail:

**4.1** Sunlight heats up dark objects. If these are in contact with or in close proximity to the glazing, local **heat build-up** may occur which causes dangerous **stresses** in the material. The sheets may crack as a result. This can be avoided if the surfaces facing the underside of the sheets are kept at some distance and are either provided with a durable **white** coating, e. g. **with lightfast white emulsion paint** (dilutable with water, low in solvent, for example exterior house paint), or durably covered with **reflective aluminum foil** (stapled to wood or bonded to painted substructure) (Fig. 4).

**4.2** This pretreatment of the surfaces of the loadbearing structure is also required for impregnated and natural, light-colored wood, in which case the aluminum foil suppresses harmful exhalations of the wood.

**4.3** Mill-finish, silver-anodized or light-colored aluminum glazing bars are not normally prone to heat build-up. If they have a dark anodized finish, the surface facing the sheets must be freed from the oxide film e. g. by sanding, in order to restore the reflective aluminum color.

**4.4** Heat insulating materials, foams (even white) Styropor®, wood paneling and the like should **not be installed directly behind** sheets exposed to the sunlight.

**Interior shading devices** (roller and venetian blinds, curtains etc.) are to be white or reflective and compatible with the sheet and should be fixed at a distance to the glazing of at least 120 mm (with vent holes!).

Avoid wide, boxlike closed areas behind/beneath the sheets. They are created by using double flashings or sealing sections above the purlin in the eaves area and may result in craze inducing-heat buildup, even if lined with reflective or white material. Therefore use **only one** sealing section (e. g. EAVES FILLER STRIP, see Fig. 8a).

**4.5** Glazing systems, and especially their upper clamping strips that are exposed to the sunlight, should also be light in color (mill-finish, silver-anodized or light-colored aluminum, white PVCu). If an additional cover section is used to conceal the screws, this may also be dark in color. Corresponding tests have shown that it will not transfer an excessive level of heat, such as might damage the sheets, to the clamping system below.

Materials like copper, which become darker with time may be a problem when used for surrounds that project over the glazing.

**Do not use wide black rubber gaskets!** Dark colored sealing gaskets are in concern of heat build-up only without risk, if their width does not exceed 15 mm.

Fig. 4: Surface of the load bearing structure

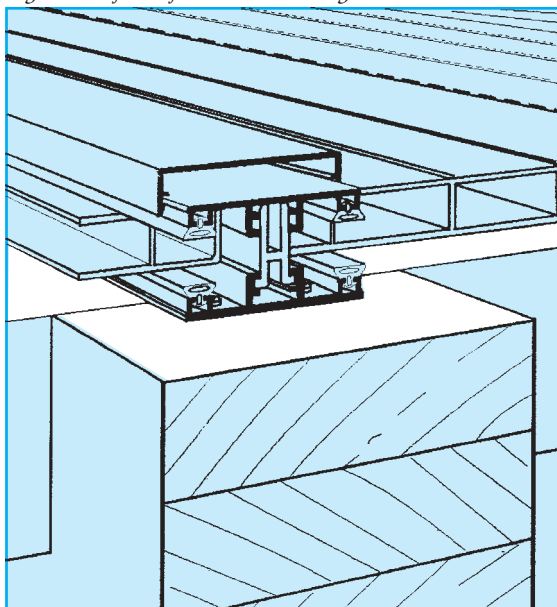

**In a nutshell:**

- Use only compatible sealants, cleaning agents, etc.!
- No silicone! (Exception: sealing of the end closure section on the outside)

*In detail:*

**5.1** Like all other plastics, PLEXIGLAS® may be attacked by certain substances. To avoid crazing, only **compatible** gaskets, clamping sections, sealants, cleaning agents, etc. may be used. To be prevented by all means is contact with plasticized PVC, point solvents, insecticide sprays, impregnating agents, powerful industrial cleaning agents and other aggressive media! In doubtful cases ask your supplier.

**5.2** If the buffs and edges of glazing bars need to be additionally sealed, make sure to use only compatible sealants, such as a suitable **silicone** (see point 10). The vapors given off during curing must not penetrate **into the hollow chambers of the sheets** as they may cause crazing. On the sheets themselves, silicone sealants may only be used to seal the upper lip of the Sheet section (Fig. 5) at the lower sheet end. Take care not to close the lateral ends of the section!

Fig. 5: Silicone sealing

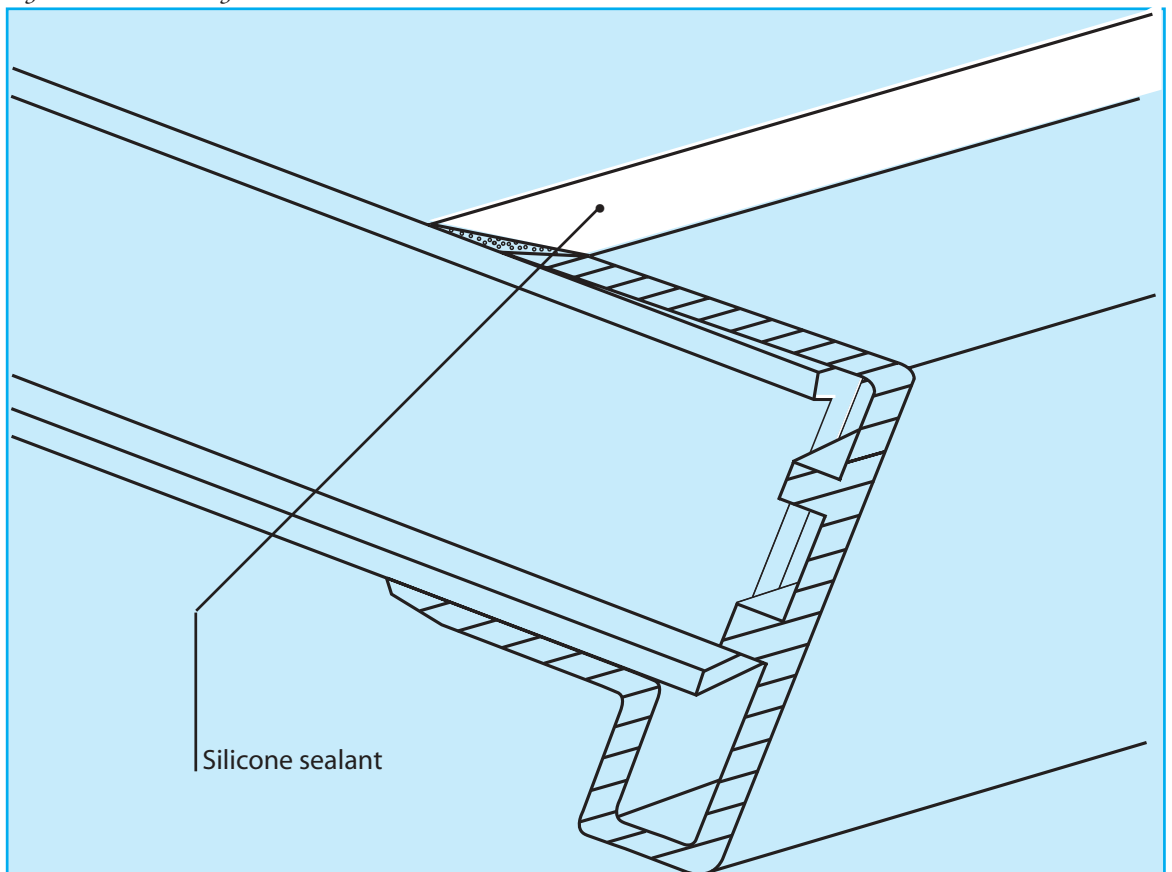

## In a nutshell:

- Use high-speed circular saws with unset, multi-tooth carbide-tipped blade!

## In detail:

**6.1** Marking should be done on the masking which ought to be left on the sheet while working with it and until it has been installed. The use of scribes or punches is prohibited to avoid breakage due to notch stress.

**6.2** Most suitable are **high-speed** circular saws with a cutting speed of about 50 m/sec. An **unset, multi-tooth carbide-tipped blade** suits the material best (Fig. 6a).

**6.3** For curved cuts and recesses, jig saws (**without** pendulum stroke) as well as fret saws and small hack saws may be used. All corners must be radiused. Drill a hole first at the corner and then cut to it from the sheet edge.

**6.4** Particularly clean cuts are achieved if

- the tools are new (and not used for other materials in between);
- a stop is used to prevent the saw from tilting and thus, possibly, the sheet from splitting (Fig. 6b);
- the blade protrudes only slightly beyond the PLEXIGLAS® sheet;
- the sheets are secured against vibration, i.e. are firmly held.

If the sheet width has to be reduced, the cut edge should be maximally 3 mm away from the last web so that the clamping action of the glazing bars is still ensured.

If the skin of a cut-to-size sheet of SDP 16 (with a web spacing of 32 or 64 mm) is to protrude more than 15 mm beyond the last web, INFILL SECTION 16 (Fig. 6c) has to be inserted into the cut edge to ensure that this sheet can be perfectly held by the glazing bar.

**6.5** Rough saw cuts can be deburred by filing.

**6.6** Swarf that has entered the chambers of the sheets can be blown out with compressed air or taken up by means of a vacuum cleaner. Swarf clinging to the edges can first be removed with a soft wire brush (e.g. sparking plug brush).

Fig. 6a: Multi-tooth saw blade

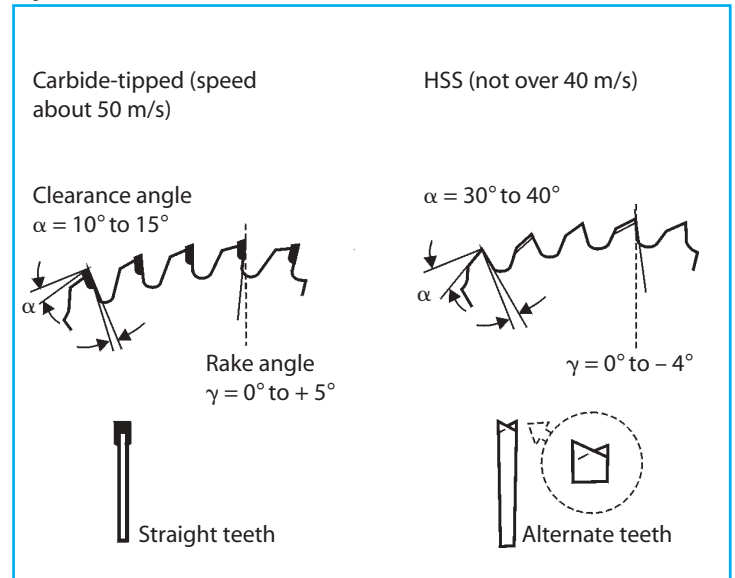
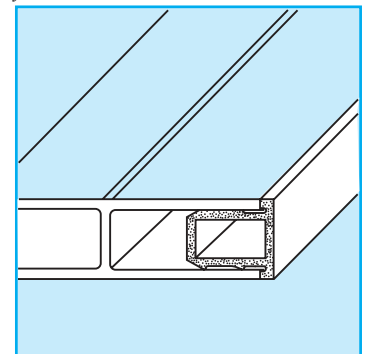

Fig. 6b: Sawing with a stop



Fig. 6c: INFILL SECTION 16 for SDP 16



## In a nutshell:

- Avoid drilling PLEXIGLAS® multi-skin sheets (exception: special tools for pre-drilling corners, etc.)!

*In detail:*

**7.1** PLEXIGLAS® multi-skin sheets must **not be drilled** but are to be installed by means of suitable glazing bars. The exception is pre-drilling of a radiused hole for cut-out corners (see chapt. 6.3).

**7.2** Suitable drills are for PLEXIGLAS® multi-skin sheets (Fig. 7)

- twist drill with special bit for PLEXIGLAS® (= drill must "scrape rather than cut"),
- conical drill,
- step drill.

Fig. 7: Suitable drills

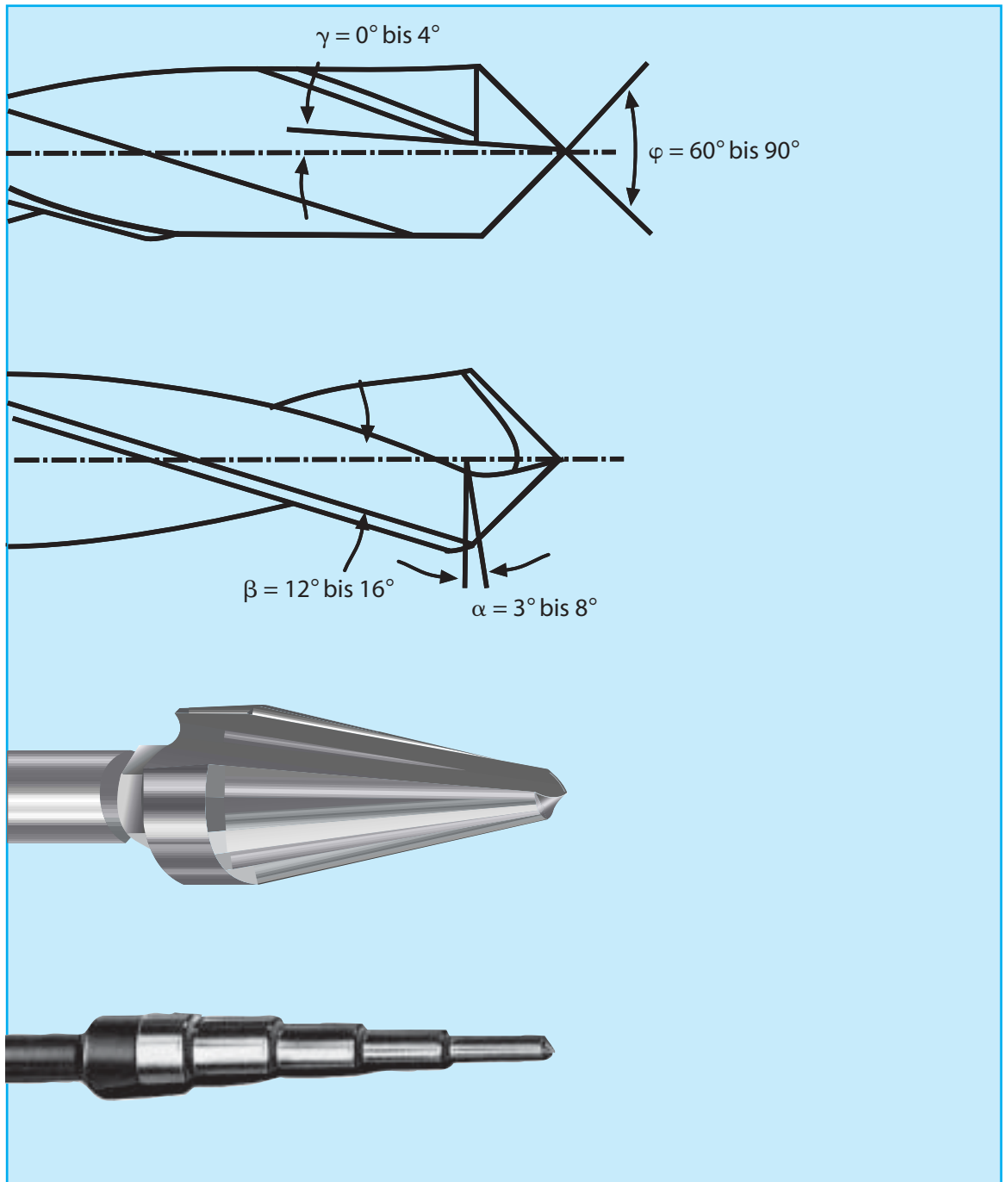

## In a nutshell:

- Close lower sheet ends providing, for **ventilation**, **seal** upper ends!
- Direction of the webs = direction of slope or water flow!

## In detail:

**8.1** For interior applications, such as exhibition stands, partitions, suspended ceilings and the like, the sheets may also be installed horizontally without paying attention to the direction of the webs. Out of doors, however, they must be installed with their webs in the direction of the slope or water flow. This is to ensure that condensate can drain away at the lower sheet end and the growth of algae and moss in the chambers is impeded (see also 3.6).

**8.2** For outdoor applications there is a basic rule to be observed for closure of the open sheet ends (also for triangular cuts):

- **at the bottom as tight as necessary!**
- **at the top as tight as possible!**

This means that the **lower** sheet ends must be protected against the penetration of dirt, water and insects while providing for **ventilation of the cavities** and draining or evaporation of condensate. If the sheet ends are not enclosed in suitable sections, proceed as follows: **Push on a Sheet section** (ease on from the front, not from the side!) after removing manufacturer's device for protection during transport (e.g. adhesive aluminum tape) such as

- Sheet section 6003 ...6008 for multi-skin sheets of according thickness (Fig. 8 b+c).

This means for the **upper** sheet ends that the cavities have to be sealed against the penetration of dirt and water and so as to **avoid air passage** as far as possible. Procedure:

- Either **push on a Sheet section** – as described above – (using Sheet section 6003 or 6004 with drip channel on the upper side) for all SDP 16, however **without** clamping this section as you cope the rubber sealing strip of the glazing system;
- or **apply additionally adhesive aluminum tape** to close the open end;  
NOTE: The adhesive tape meant for protection during transport need not be removed from the upper sheet end when the Sheet section is applied;
- or: The **optimum** combination consists in **pushing on a Sheet section and closing its**

**lateral openings with adhesive aluminum tape.**

**8.3** For installation you may only use glazing systems and fastening elements designed for use with the sheets, e.g.

- assembly accessories from Röhm (**not self supporting**, Fig. 8a),
- special glazing systems from PLEXIGLAS® stockists,
- patent glazing systems for metal structures and greenhouses.

The appropriate bar spacing have to be observed (cf. 2.6)

Installation procedures of our **PROFESSIONAL GLAZING/CLAMPING SYSTEMS** are much the same way. Furthermore we offer the **PROStyle® Assembly Systems** with interesting advantages. They have different sequences of installing being explained in separate brochures.

**8.4** In inclined roof structures the sheets must be prevented from sliding down. To this end they can be secured with Aluminum Terminal Angles fastened at the clamping sections along the eaves (Fig. 8c). Under the sheet's own weight these angles provide a **firm base** of the lower ends, so that **expansion** can only take place of the **upper ends** and must be allowed for there (according to 2.4). The clear space to the wall is covered with the PROFESSIONAL WALL CONNECTING SYSTEM, whose sealing strips need to be coped where they project from the cover section of the connecting system. (Fig. 8d).

**8.5** Surface modified sides of multi-skin sheets are installed facing

- **upwards/outwards:**
  - HEATSTOP coating (reflection of sun-heat)
- **downwards/inwards:**
  - C-texture (protection against dirt pickup)
- **optionally** outwards or inwards (no preferred direction)
  - NO DROP <sup>1)</sup> coating,
  - ALLTOP coating (because sheet is coated on all sides + inside cavities).

<sup>1)</sup> European patent EP 149 182

Fig. 8a: Glazing systems from Röhm

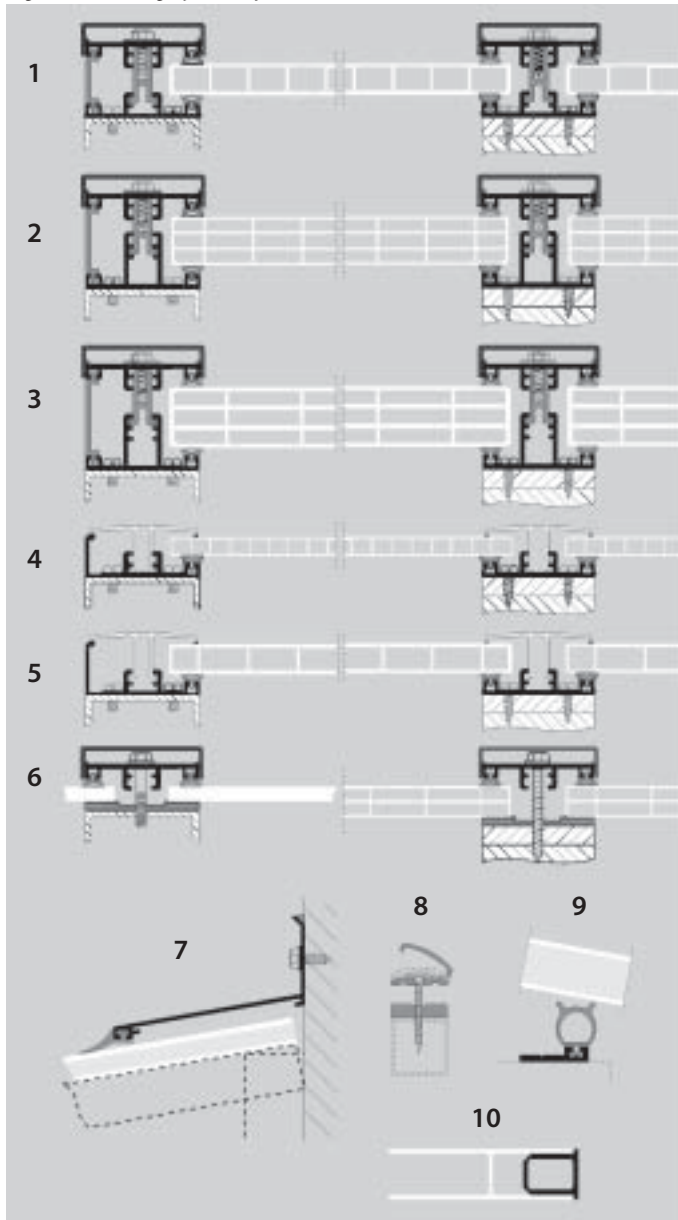

- 1 = **PROFESSIONAL THERMOGLAZING SYSTEM 16:**  
for 16 mm thick multi-skin sheets
- 2 = **PROFESSIONAL THERMOGLAZING SYSTEM 25:**  
for 25 mm thick multi-skin sheets
- 3 = **PROFESSIONAL THERMOGLAZING SYSTEM 32:**  
for 32 mm thick multi-skin sheets
- 4 = **PROFESSIONAL CLAMPING SYSTEM 10:**  
for 10 mm thick multi-skin sheets
- 5 = **PROFESSIONAL CLAMPING SYSTEM 16:**  
for 16 mm thick multi-skin sheets
- 6 = **PROFESSIONAL BASE-PLATE SYSTEM:**  
for all PLEXIGLAS® solid sheets as well as polycarbonate multi-skin sheets
- 7 = **PROFESSIONAL WALL CONNECTION:**  
for horizontal and vertical wall flashings in roofs glazed with PROFESSIONAL GLAZING SYSTEMS
- 8 = **POINT FIXING BUTTON:**  
additionally **only** for polycarbonate multi-skin sheets, pointwise fixing on rafters or purlins (screw is meant for metal); 2 designs: with 7.5 mm washer for the PROFESSIONAL BASE-PLATE SYSTEM or 12 mm washer for all other PROFESSIONAL GLAZING SYSTEMS.
- 9 = **EAVES FILLER STRIP:**  
for sealing the air gap between multi-skin sheets and the upper side at the purlin or crossbar of the lower (and sometimes upper) end of the roof or wall of buildings, e.g. conservatories, etc.
- 10 = **INFILL SECTION 16:**  
guarantees clamping action of glazing bar when cutting sheets lengthwise > 15 mm away from the last web.

1 to 6 are suitable for supporting structures made of metal or wood (laminated timber beams), but not self supporting.

Fig. 8b: Sheet section 6004 and 6003

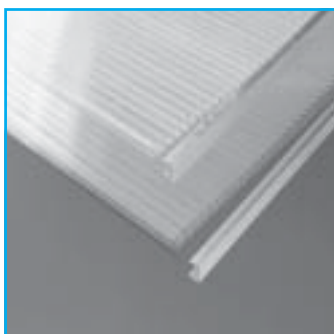

Fig. 8c: Aluminum terminal angle

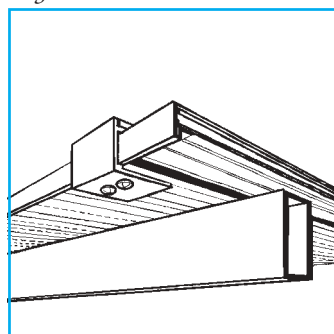
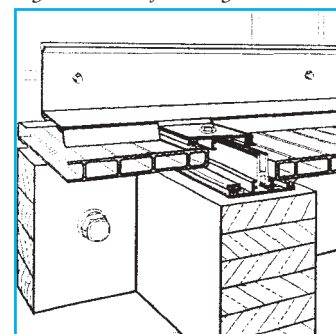

Fig. 8d: Wall flashing



**In a nutshell:**

- Condensation in the chambers is unavoidable!
- Crackling noises due to expansion are possible!
- Always use a crawling board for walking on the sheets!

*In detail:*

**9.1** Condensation is a natural phenomenon. PLEXIGLAS® is slightly permeable to gas and vapor. For these reasons it is practically impossible to seal their chambers hermetically. Given the corresponding weather conditions, moist air may enter the chambers to cause **fogging and condensation**. This has no influence on the material properties or the function of the sheets. If suitable **vent holes** are provided at the lower sheet ends (see 8.2), condensate can drain away or evaporate.

In the case of the **NO DROP** sheet with its water dispersing coating on the inside, condensation on the surface facing the room is almost **invisible** and **does not drip down** and the room stays brighter. If, instead, the NO DROP surface faces outwards, this enhances the self cleaning effect by rain and moisture and the sheet dries quickly. The NO DROP coating is covered by a protective layer applied during manufacture. This layer is

washed off by condensation or rain; whereupon the NO DROP coating is activated. The protective layer can, however, also be removed manually using water and a sponge or by hosing the sheet down.

**ALLTOP** sheets are provided with a water-dispersing coating on both sides and within the cavities, so that condensation remains **more or less invisible** throughout. When working with NO DROP and ALLTOP sheets please note:

- thermoforming reduces the effect of the coating.
- ACRIFIX®, silicone and other adhesives will not adhere perfectly unless the coated surfaces have been carefully cleaned with water and some dish-washing liquid.

*Fig. 9a: Function of NO DROP / ALLTOP coatings*

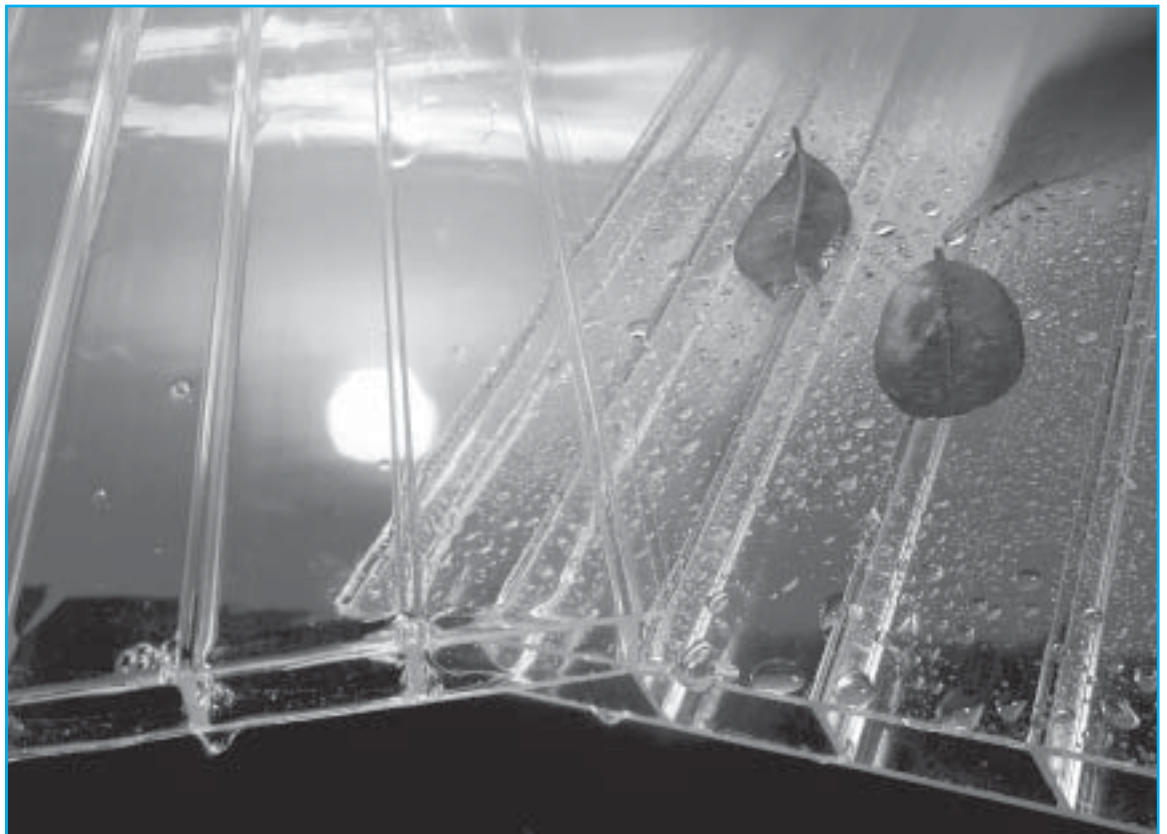

**9.2** Due to static friction in the clamping areas, the sheets may expand suddenly, causing **crackling noises**. This movement has no influence on the useful properties of the sheets and glazing bars. If glazing systems are used which hold the sheets between rubber gaskets, the expansion noises are drastically reduced. This is the case with our PROFESSIONAL GLAZING/CLAMPING SYSTEMS, whose sealing strips are nevertheless coped at the **upper** sheet ends in order not to clamp the Sheet sections and thus to reduce the noise potential. Other structural elements may cause the same noises, however.

**9.3** Being an acrylic, PLEXIGLAS® shows natural, **excellent weather resistance**. We guarantee for 10 years that it does not turn yellow, become brittle or lose its rigidity.

**9.4** PLEXIGLAS® SP are highly break-resistant and sufficiently **hail-resistant** under ordinary conditions. Impact-modified PLEXIGLAS RESIST® SP and PLEXIGLAS HEATSTOP® SP multi-skin sheets are particularly resistant. PLEXIGLAS RESIST® SP are guaranteed hail-resistant (1 joule).

**9.5** The general safety regulations for non-load-bearing roofings apply. In order to avoid damage to the outer skins of the sheets, they should only be **walked on with boards**.

**9.6** Apart from observing the regional building regulations it must be borne in mind that PLEXIGLAS® multi-skin sheets are rated Class 4 to BS 476, part 7.

**9.7** Given an adequate roof pitch, or vertical glazing, it is not normally necessary **to clean** the sheets on the outside. Any dirt is washed down by the rain. Cleaning may be required in certain locations (e.g. under trees or in the vicinity of plants). When the sheets are installed as secondary glazing, the gap between the existing glazing and the multi-skin sheet must be cleaned with water and dried before the unit is sealed. The inside of glazing, partitions and other interior objects can be cleaned

with clear warm water to which some dishwashing liquid has been added. Often all you need is a soft, moist cloth or a sponge. For antistatic treatment there is the Antistatic Cleaning Agent by Burnus GmbH, Darmstadt, which is available from your stockist (Fig. 9b).

Do not use aggressive cleaning agents, insecticides, etc. (see also 5.1).

**9.8** Multi-skin sheets in flat roofs may bow or sag, in which case the deformation may become particularly options along the eaves, especially if they project. Where a sealing section is used at the eaves, between the sheets and the supporting structure, this section must be able to absorb the deformation and be compatible with the glazing material (acc. to 4 and 5.1). We recommend the use of our EAVES FILLER STRIP (Fig. 8a, section 9).

*Fig. 9b: Cleaning*





Certified to DIN EN ISO 9001 (Quality)  
and DIN EN ISO 14001 (Environment)

[www.plexiglas.de](http://www.plexiglas.de)  
[info@plexiglas.de](mailto:info@plexiglas.de)

Our technical advice on the applications of our products is given without obligation. The buyer is responsible for their use and processing, and is also liable for observing any third-party rights. Technical data concerning our products are typical values. Subject to alteration.

**Important notice**

This is an international English-language information prepared for several markets. It is essential that the selection of particular materials and their methods of use conform with the requirements of national and local Building Regulations.

® = registered trademark

**PLEXIGLAS,  
PLEXIGLAS RESIST,  
PLEXIGLAS ALLTOP,  
PLEXIGLAS HEATSTOP,  
ACRIFIX**

are registered trademarks of  
Röhm GmbH & Co. KG, Darmstadt, Germany.

Advice and delivery by: